

Navigator Stove Works, LLC.

www.marinestove.com



HALIBUT Marine Stove

Installation and Operating Instructions

SAFETY NOTICE: IF THIS SOLID FUEL MARINE STOVE IS NOT PROPERLY INSTALLED AND OPERATED, A BOAT FIRE MAY RESULT. FOR YOUR SAFETY, FOLLOW THE INSTALLATION DIRECTIONS. CONTACT YOUR LOCAL COAST GUARD, MARINE SURVEYOR, OR FIRE OFFICIALS ABOUT RESTRICTIONS AND INSTALLATION INSPECTION REQUIREMENTS IN YOUR AREA.

TABLE OF CONTENTS

GENERAL INFORMATION

MARINE INSTALLATION

1. POSSIBLE HAZARDS TO AVOID WHEN USING THE HALIBUT.
2. INSTALLATION & SAFETY NOTICE
3. OPERATION
4. MAINTENANCE

WARNING

DO NOT LEAVE THIS STOVE
UNATTENDED WHILE IN OPERATION

SAFE OPERATION OF THIS
MARINE STOVE IS THE PRODUCT
OF TWO FACTORS:

A CAREFULLY TENDED FIRE AND
PROPER INSTALLATION

General Information

This owner's manual describes the installation and operation of Navigator's **HALIBUT Marine Stove** for wood & coal. This model is not an EPA certified residential wood heater. It is EPA exempt and falls under EPA's 2015 "camp stove" category. This marine stove may be installed within a boat or temporary structure for portable and temporary use while hunting, camping, fishing or other outdoor recreation.

Codes and Regulations compiled from the following sources serve as the basis for the instructions contained in this document:

ABYC "A-7"	*1
NFPA "302"	*2
NFPA "211"	*3
40 CFR 60 - AAA	*4
CAN/CSA B365-M91	*5

(See Appendix for Details)

This wood heater needs periodic inspection and repair for proper operation. It is against federal regulations to operate this wood heater in a manner inconsistent with operating instructions in this manual.

When installing, operating, and maintaining your **HALIBUT**, follow the guidelines given in these instructions. Save these instructions and make them available to anyone using the stove.

Please contact your insurance representative, marine surveyor, US & CDN Coast Guard, or local fire officials to determine what regulations apply in your area.

MARINE INSTALLATION

1. Possible Hazards to Avoid

Any use of fire in a boat represents a certain danger. With intense overfiring, temperatures on the surface of the **HALIBUT** can exceed 1000° F. (536° C).

Comply with the following guidelines:

- Never install a **HALIBUT** in a boat that is powered by a gasoline engine.
- Never over fire the stove. If any part of the stove or chimney glows, you are over firing, and a boat fire or serious damage to the stove or chimney could result. Immediately close down the air controls if you notice this condition.
- Teach children that the stove is hot and must not be touched.
- Never use gasoline, or gasoline-type lantern fuel, kerosene, diesel, charcoal lighter fluid or similar liquids to start or "freshen up" a fire in the stove. They can ignite with explosive force, causing bodily injury or death. Keep all such liquids far away from the stove while it is in use.
- Never use the stove if there are combustible vapours in the boat. The vapours from certain cleaning fluids, adhesives, and polyurethane paints are a few examples of combustible vapours. Remember that operating a solid-fuel fired marine stove is a source of "open flame".
- Keep combustible materials far away from the stove.

- A vent system or other means shall be provided to allow the discharge from the boat of hydrogen gas released by the battery. Battery boxes with a cover that forms a pocket over the battery shall be vented.
- Do not locate traditional marine oil lamps directly over the stove. Oil spillage onto a hot stove will cause a fire.
- Do not dry clothes over the stove, since they could fall and ignite.
- Fabrics located above and within 39” of the stove used for decorative or other purposes shall be flame resistant in accordance with NFPA 701, *Standard methods of fire tests for flame-resistant textiles & films*.
- To prevent injury, do not allow anyone to use this stove who is unfamiliar with the correct operation of the stove.
- Avoid creating a “Low Pressure” condition in the space where the stove is operating, such as by operating an exhaust fan. A low pressure condition could cause poisonous gasses to be drawn out of the stove and into the room. **Carbon monoxide** is toxic, so please follow the guidelines in this manual to avoid smoke “roll out” from the burn chamber. You can prevent a low pressure condition by providing adequate outside combustion air within 24 inches of the stove. Keep a port, hatch, or window open while operating the stove!

Install a carbon monoxide monitoring device and maintain it as directed by the manufacturer.

- If for some reason smoke “rolls out” of the stove, it might activate a smoke alarm or carbon monoxide detector.
- To avoid smoke or flame spillage, open the air adjuster and the stove pipe damper before opening the door to fill the stove with fuel.
- Never operate the stove if it is damaged, missing parts, or has been modified in any way.
- Do not burn synthetic fire place logs in the stove. Use only natural wood or coal or hardwood charcoal.
- To prevent spontaneous combustion, coal & charcoal shall be kept dry and stored in a closed, dry metal container.
- Always use protective gloves when adding fuel to the fire.
- Do not operate the stove during severe storm conditions at sea. Stow cook surface cover plates, air adjuster and handles.

2. Installation

SAFETY NOTICE: IF THIS SOLID FUEL MARINE COOK STOVE IS NOT PROPERLY INSTALLED AND OPERATED, A BOAT FIRE

MAY RESULT. FOR YOUR SAFETY, FOLLOW THE INSTALLATION DIRECTIONS. CONTACT YOUR LOCAL COAST GUARD, MARINE SURVEYOR OR FIRE OFFICIALS ABOUT RESTRICTIONS AND INSTALLATION INSPECTION REQUIREMENTS IN YOUR AREA.

Please read this entire manual before you install and use your new stove. Failure to follow instructions may result in property damage, bodily injury, or even death.

We recommend that you have your HALIBUT Installed by a professional installer of solid-fuel marine stoves.

Remove Stove From Crate

CAUTION

Two people are required to uncrate & position the 175 Lb. stove. Please do not try to do it alone. Your back will thank you.

When removing the stove, **Do not lift the stove by it's bronze "sea rail."** This part is only designed for keeping cook pots in place while at sea. Lift the stove free from the crate by grasping the outer-most edges of it's cast iron top.

During the installation process please remember that the stove is cast iron and not steel. Cast iron unlike steel will crack rather than bend when subjected to excessive force. The fasteners which have been used to assemble the stove have only been tightened to roughly ¼ turn past "finger tight".

DO NOT OVER TORQUE:

LEG SET SCREWS.

4 WINGNUTS on the underside of stove that terminate the long body bolts.

SEA RAIL CORNERPOST fasteners.

OVEN CLEAN OUT PLATE screws (if fitted for).

TURNBUCKLE ATTACHMENT points on left & right sides.

Carefully remove the legs, cover plates, shaker grate handle and cover plate handle from inside the fire box or oven.

Installing the Legs. Using a thin pad to cushion the stove, carefully tip it 45 degrees onto its front edge. Pay attention to the firebox liners as they are simply held by gravity and will fall out of place if turned upside down. Install rear legs first. Each leg has a dovetail slot and fits into its corresponding "dimple numbered" slot. A mirror could help to identify which leg goes

where. Tighten the set screw to fix its position.

Changing the WOOD and COAL front firebox liner plates. The stove is delivered with the wood liner in place. To switch over to the horizontal bar liner for coal burning, reach your hand inside the firebox through the 6" coverplate opening. The wood liner slides UP, and then to the rear. Remove liner through coverplate opening. Generally, coal loads through the top of the stove and wood through the upper firebox *ROBAX* glass door.

Place the two circular cover plates in their places on the cook surface.

Planning the Installation....

If you are considering installing a HALIBUT in a vessel which has a previously installed stove hearth and/or chimney pipe, it is critical that you have the existing components inspected for safety.

Safe stove installation involves several aspects: (A) the chimney pipe / deck iron combination. (B) protecting combustible materials in the vicinity of the stove. (C) securing the stove. Each of these aspects is equally important for a safe and secure installation. Consult with a Marine Surveyor.

A. Chimney Pipe

The chimney pipe should be of 4" Dia. stainless steel with a minimum thickness of 26 gauge. Secure sections of pipe together with three sheet metal screws per joint to insure that the sections will not separate.

NOTE: At the stove to pipe connection, the pipe is hand formed to fit OVER the stove's cast collar.

Single-wall smoke pipe and stacks shall have a **minimum clearance of 9 inches (23 cm.) from combustible materials including painted materials** or shall be separated by fire resistant thermal insulation that is acceptable to the authority having jurisdiction. *NFPA Standards #302 / 211*

Consult with a Marine Surveyor to determine the protection system best suited for your installation if you cannot maintain the minimum 9" clearance. This system will commonly consist of a layered panel, made from 20 Ga. sheet stainless and 5/8" non asbestos mineral board, spaced 1" from the combustible surface to which it is attached.

***Exception: at decks equipped with a water iron.** (NFPA 302, 6 - 3.3)



Water Deck Iron

Either a bronze or a cast iron “water deck iron” shall be used. This traditional fitting contains water in a trough which surrounds and cools the chimney pipe as it passes through the deck. Follow manufacturer’s installation & operation instructions when installing this hardware. Keep the trough filled with water while operating the stove.

A flue damper shall be installed in the pipe no less than 21” above the cook surface of the stove. The damper is a critical component which will enable the user to control the stove’s draft. **Do not install a HALIBUT without a damper.**



Flue Pipe Draft Damper

Do not use aluminum or galvanized pipe as chimney pipe. These materials cannot withstand the operating temperatures of a fire and can give off toxic fumes when heated. Round stove pipe must be hand formed to an oval shape which will then slide onto the stove’s oval flue collar.

The connection between the 4” chimney pipe and the stove’s oval flue collar shall be sealed with stove cement or a piece of stove gasket material. Design the piping so that no more than a total of two 90 degree bends are utilized. Horizontal runs shall rise at 1/4 inch per foot.

Chimney piping may not be run through a closet, locker or other concealed space. Always connect this stove to a chimney and vent to the outside of the vessel. Install a Smoke Head which is designed to minimize water entry, spark emission and backdraft. In very bad weather do not operate the stove. Safely stow the smoke head and install a deck plug which will effectively seal the deck iron’s opening in the event of the vessel overturning.



Smoke Head

Additionally, install a UL listed spark arrester if the smoke head you have chosen does not incorporate one into it’s design.

Do not position the deck iron / smoke head combination within 20” of deck mounted fuel refill fittings or fuel tank vents. Position the smoke head to

minimize exhaust re-entry into the boat.

B. Clearances to Combustibles

Floor Protection....

The **HALIBUT** shall be mounted on a non-combustible base (preferably a composite panel of 20Ga. stainless steel and non-asbestos mineral board).

As well as being non-combustible, the base **must have a minimum R-Value (thermal resistance) of R2.**

For example, 1/2" of **Micore 300** mineral board has an R-Value of 1.09.

A minimum clearance of **1"- 25mm** shall be maintained between the composite panel and the "decking" to which it shall be securely fastened. Mounting hardware which extends from the panel into combustibles may be used only at the lateral extremities of the panel. Mounting hardware must allow full ventilation of the air space between the "deck" and the composite panel.

The non-combustible base, or "deck protector panel", shall extend out from the sides and back of the stove to exactly **1"** from all adjacent vertical surfaces surrounding the stove. (i.e., walls, bulkheads, hull, cabinetry, furnishings which will normally be protected by an engineered protection system. See Diagram #3).

The "deck protector panel" shall extend out from the front of the stove a distance equal to the dimension of the underlying platform.

Floor protection shall also be used under the stove pipe and must extend 2" beyond either side of the pipe.

CAUTION: First install a non-combustible stove base and/or wall shielding to provide a safe under-layment for ceramic tile. Tile must not be used as the sole form of thermal protection due to its ability to conduct significant heat to combustible materials to which it may be directly attached. Ceramic tile shall be incorporated into a hearth design **only as a decorative surface treatment.**

Plastics, fiberglass reinforced plastics, wood, or paper products are combustible and must not be used.

Clearances to Adjacent Combustible Materials....

Three basic requirements determine the clearance values necessary for the stove's installation. Failure to follow these requirements may result in property damage, bodily injury, or even death.

RULE 1. Exposed materials and finishes within **24"** (61Cm) of heat generating surfaces of the stove **shall have a "flame spread index" of not more than 75** as determined in accordance with NFPA 255, *Standard Method of Test of Surface Burning Characteristics of Building Materials.*

RULE 2. The sides, back, and front surfaces of the **HALIBUT** shall have a **minimum clearance of 9” (23Cm) from the exposed combustible materials and finishes which shall meet the requirements of RULE 1**, or shall be separated by an engineered protection system acceptable to the authority having jurisdiction. Engineered systems installed for the protection of combustible material shall reduce the temperature of such materials to 90°F (50°C) rise above ambient. System design shall be based on applicable heat transfer principles, taking into account the geometry of the system, the heat loss characteristics of the structure behind the combustible material, and the possible abnormal operating conditions of the heat-producing sources.

RULE 3. Minimum clearance to combustible ceilings or materials above the cook surface of the **HALIBUT** shall be **36” (92Cm)**, or shall be separated by an engineered protection system acceptable to the authority having jurisdiction. Engineered systems installed for the protection of combustible material shall reduce the temperature of such materials to 90°F (50°C) rise above ambient. System design shall be based on applicable heat transfer principles, taking into account the geometry of the system, the heat loss characteristics of the structure behind the combustible material, and the possible abnormal operating conditions of the heat producing sources.

Marine installations will normally require considerable heat-shielding due to the fact that most boatbuilding materials or finishes located within 9” of the sides and back of the stove will not have the required rating of FSI 75 or less.

Common Bldg. Materials & Flame Spread Indices:

White Oak	100
Douglas Fir	83 - 100
Eastern White Pine	85
Southern Yellow Pine	130 - 195
Western Spruce	100
1/2” Exterior Douglas Fir Plywood	130- 150
3/4” Birch Plywood (veneer core)	114
1/2” Particleboard	156
1/4” Lauan Plywood	150
3/8” FRP (polyester & glass fiber)	200+

Micore 300 Mineral Fiber Board 25

Manufactured by US Gypsum, Inc.

<http://www.gypsumsolutions.com/htmlID/micore.asp>

Insulation material used as part of a clearance reduction system shall also have a thermal conductivity (**K-Value**) of **1.0 (Btu-in.) / (ft 2 -hr-°F) or less**. Insulation board shall be formed of noncombustible material. For example, Micore 300 has a K-value of .458.

Also see for further information:

http://hearth.com/articles/64_0_1_0_M1.html

Please Remember....

A combustible is anything that can burn. In the case of stove installations, these materials **may not be plainly visible**. Consult your local fire officials if you are unsure about the combustible nature of a material in the vicinity of your planned stove installation. Fire resistant materials are difficult to ignite but they will burn!

Diagrams #1 & #2 give the required clearances that must be maintained from unprotected combustible materials or finishes.

Diagram #3 illustrates an example of an *engineered protection system* that would be used to shield combustible materials.

Consult with your local Marine Surveyor to determine suitable design parameters for your particular vessel

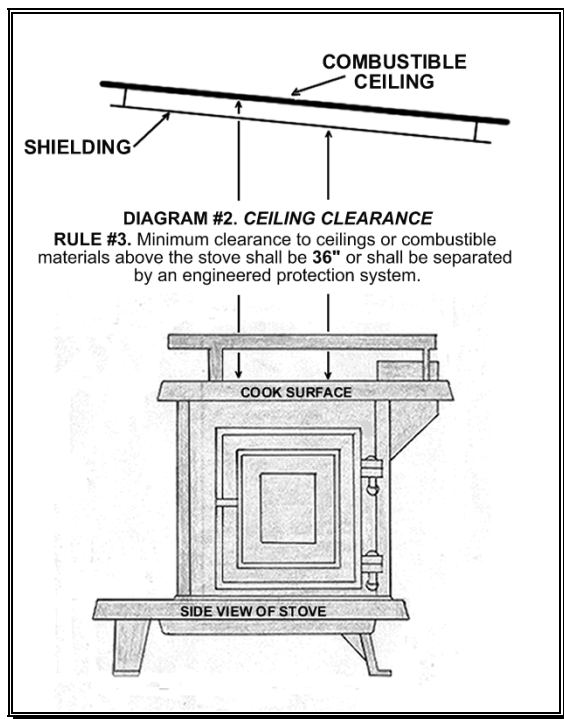
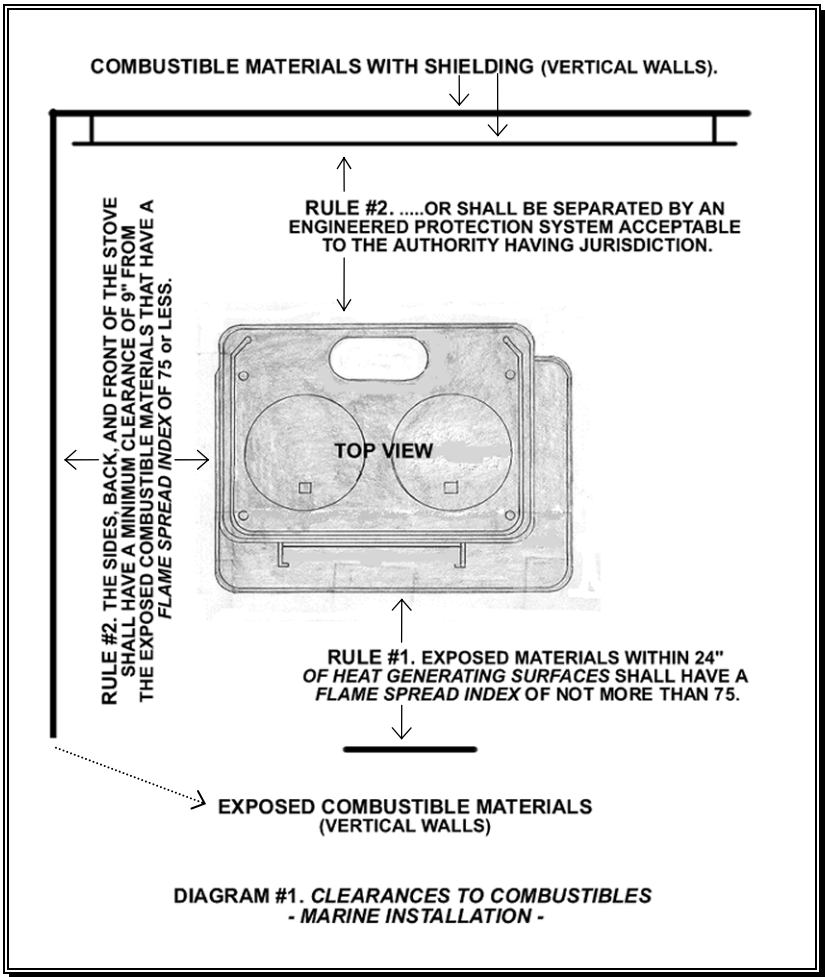

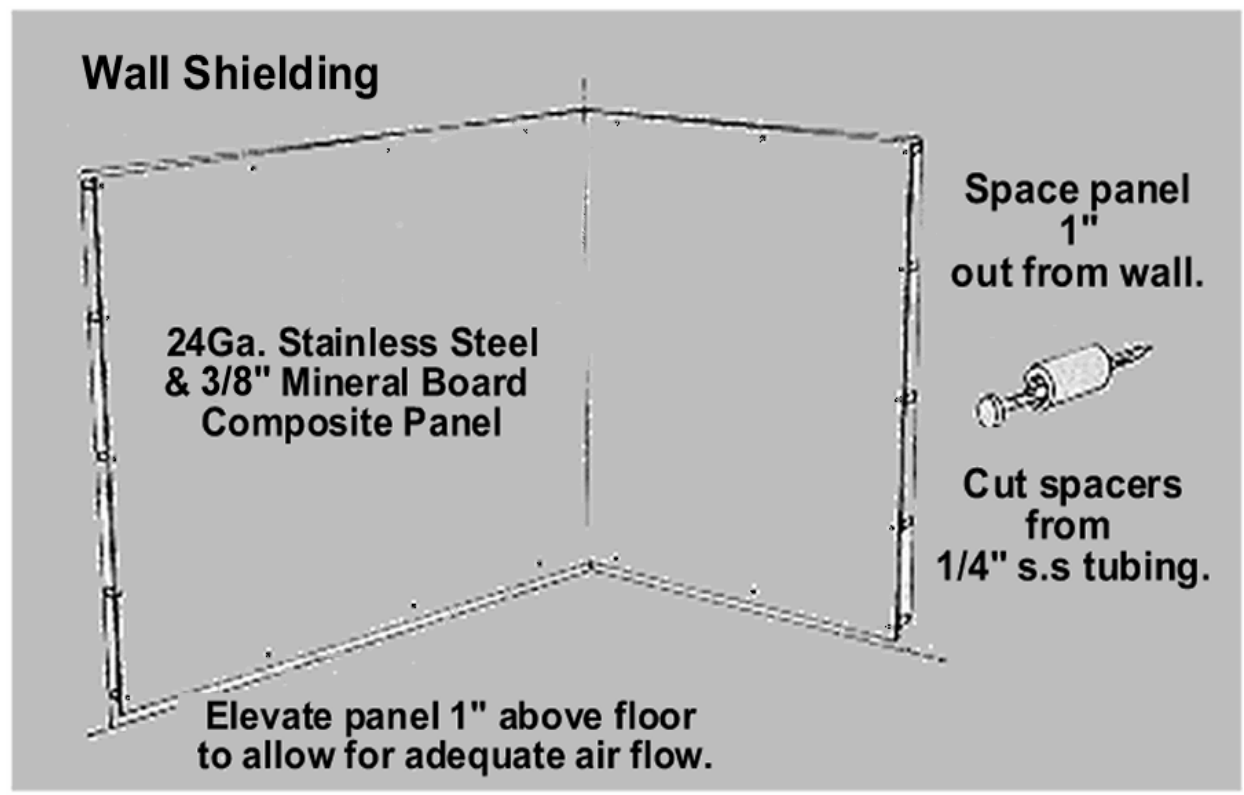

DIAGRAM #3.

Shield Construction Specifications:

- 1) Minimum space between shield and combustibles: 1" - 25 mm
- 2) Minimum clearance along the bottom of shield: 1" - 25 mm
- 3) Maximum clearance along the bottom of shield: 3" - 75 mm
- 4) Minimum clearance along the top of shield at ceiling: 3" - 75 mm
- 5) Edge clearance for ceiling shields: 3" - 75 mm
- 6) Adhesives used in shield construction must not ignite or lose adhesive qualities at temperatures likely to be encountered.
- 7) Mounting hardware must allow full vertical ventilation.
- 8) Mounting hardware must not be located closer than 200 mm (8 in.) from the vertical centre line of the appliance.
- 9) Mounting hardware which extends from the shield surface into combustibles may be used only at the lateral extremities of the shield.

NOTE: Workshops which fabricate stainless restaurant equipment are great (cost effective) sources for stainless shielding materials. Make plywood templates of the required shields and have your local supplier quote a price. Consider hiding the mineral board edges by bending-over the edges of the

metal by 1/2". Doing so will require minimal welding at each of the four corners which these shops are normally set up to do. Also, consider orienting the surface texture, or grain of the metal either all horizontal, or all vertical (if you care). This method of dealing with the shielding issue has yielded high quality results which would have been hard to match otherwise.

C. Securing the Stove....

The stove's legs have holes which shall allow you to safely anchor it in place. We suggest that you use 1/4" stainless steel bolts with oversize washers, lock washers, and all-metal locking nuts. **Do not use plain screws** as they might not hold the stove in place during a violent storm. Attach the stove to its base before installing the smoke piping. Carefully observe the required clearances to combustibles.

Installing Turnbuckle Hold Downs.

In order to reduce stress on the leg hold down fasteners & to assure that the stove does not move aboard a rocking boat, install two 1/4" clevis pin size turnbuckles. Centered within the compass roses on the L& R stove sides are the attachment points. Tighten body of turnbuckle until slack is removed between stove and platform mounted eye. DO NOT OVERTIGHTEN. Pin to pin about 9" is required.

3. Operation.

Before building a fire in your new stove, please read the following section carefully.

Mount the supplied "Warning" plaque in the vicinity of the stove such that it is clearly visible while operating the stove.

Make sure the stainless ash pan is installed behind the lower firebox door.

This stove is designed to burn natural wood, hardwood charcoal and coal. Higher efficiencies and lower emissions generally result when burning air-dried seasoned hardwoods, as compared to softwoods or to green or freshly-cut Hardwoods.

Do not burn:

- Treated or Painted Wood
- Garbage
- Chemical Chimney Cleaners
- Cardboard
- Colored Paper
- Solvents
- Any synthetic fuel or logs that have not been approved for wood stoves.

Burning treated wood, garbage, solvents, colored paper, chemical chimney

cleaners, or trash may result in the release of toxic fumes. Never use gasoline, gasoline-type lantern fuel, kerosene, charcoal lighter fluid, or similar liquids to start or "freshen up" a fire in this heater.

Keep all such liquids far away from the heater while it is in use.

Wood & Coal Storage.

To prevent spontaneous combustion, coal shall be kept dry and stored in a closed, dry metal container.

When storing wood, it should be covered and stored off the ground to protect it from the elements. Make certain that the wood-pile has good air circulation through it in order to promote drying to aid in the seasoning process.

To obtain the best performance from your stove, we recommend using seasoned hardwood that has been dried and stored under cover for at least one year. Burning unseasoned or wet wood causes the rapid development of creosote and reduces the heat value of the wood being burned.

Creosote and Soot Formation and the Need for Removal.

When wood is burned slowly, it produces tar and other organic vapors which combine with expelled moisture to form creosote. These creosote vapors condense in the relatively cool chimney flue of a slow burning fire. The creosote that accumulates in the flue is highly flammable and is the fuel of chimney fires. To prevent a chimney fire, the creosote needs to be removed by sweeping the chimney and flue connector. The frequency of sweeping will depend on how you operate your stove, but it is important to inspect the flue after every two weeks of use. An accumulation of 1/4" or more on the sides of the flue or connector is considered hazardous and should be removed.

In the event that creosote in your chimney ignites, the resulting fire is often accompanied by a roaring noise and a crackling sound as flakes of burned creosote break loose. If you suspect you are having a chimney fire, immediately close the draft damper and sliding air control, making sure the stove door is closed. Call the "fire department" and get everyone safely out of the boat.

Trying to extinguish the fire in the stove will not help. In fact it can make the matter worse by allowing oxygen through the door, which then supports the fire in the chimney. When the roaring and crackling has stopped, you should resist the temptation to open the door and look at the fire. The fire may have suffocated, but could rekindle when you open the door. After a chimney fire, do not use your stove until the chimney and the flue connector has been cleaned and inspected to ensure that no damage has been sustained.

Breaking in Your Stove

A cast iron stove should be "broken in" gradually. Five consecutive small fires must be built in the stove prior to operating the stove continuously. Each fire should be a little larger than the previous one, and the last fire

should be a full-sized load. Allow the stove to cool completely between fires.

Controls

To open the two fire box or oven doors, firmly raise the latch and pull the door toward you. To shut the door, raise the latch, push the door closed, and lower the latch. Make sure the door catch is securely engaged.

Air Controls

1. The disc style air control is located in the lower firebox door.

Open = Clockwise / Close = Counter clockwise.

Turning the control clockwise opens the air control and increases the heat output; turning it counter clockwise closes the control and decreases the heat output.

Turn the control fully open when first starting or reviving a fire, or when maximum heat is required.

2. Using the "START OUT / OVEN IN" slider.

Upon lighting the stove, you will want to pull OUT the stainless slider just above the oven door. This will allow a direct updraft through the stove and will bypass the circular flame path that is used to heat all sides of the oven when baking.

3. The stove pipe draft damper shall be located approximately 21" above the stove top in the chimney pipe. **Do not install a HALIBUT without a draft damper.**

Turning the handle parallel to the pipe increases the stove's draft and turning it perpendicular decreases the draft. **Always fully open the damper when starting or before refueling a fire.**

You will determine the best settings for your particular needs as you gain experience with your stove.

Building a Fire

A good fire will efficiently utilize your fuel keep emissions and creosote to an absolute minimum, require less work, and be very predictable. Make sure the air control is fully open. Open the front door and cover the bottom of the stove with tightly crumpled newspaper. Criss-cross a generous double handful of dry kindling, such as split pieces of scrap lumber on top of the paper. If you don't have scrap lumber, split some of your best dry wood down to finger-sized pieces and use that. Place three or four 1" - 2" split pieces of dry wood on top of the kindling. Light the paper evenly across the door. Continue to add 1" - 2" pieces of split dry wood until a healthy bed of glowing coals has formed. You can now add three or four small-to-medium pieces of wood. Allow this wood to burn for several minutes. Once you are sure the

wood is burning well, adjust the air controls to your desired heat output level.

If the fire dies out, the cause is most likely an insufficient bed of coals, reducing the air supply too soon, or using wood that is either too large or not dry enough.

The use of coal will generally require a wood fire initially to get the coal to burn.

HOT WHILE IN OPERATION. KEEP CHILDREN, CLOTHING, AND FURNITURE AWAY. DO NOT STORE FUEL WITHIN THE CLEARANCES LISTED PREVIOUSLY.

Reloading

Reload the stove while it is still hot and there are plenty of hot coals to ignite the fresh fuel load. It is a good idea to include a smaller piece or two of wood at the base of the new load to help the stove recover more quickly to its operating temperature.

Reloading Procedure

- Always wear gloves when tending the stove.
- Turn the air control open to the full open position.
- Open the pipe damper to the full open position.
- Pull out the Start Out – Oven In Slider to take the stove out of “baking mode” and put it into “start mode”.
- Wait a few seconds and open the door.
- Use a stove shovel or similar tool to break up any remaining charcoal.
- Load the fuel (smaller pieces first).
- Close the door.
- Wait 5 -10 minutes and adjust the air controls to desired setting.

Note: If the charcoal bed present at reloading time is relatively deep (1"-2") and your wood is well seasoned, it is possible to add the fresh fuel load, close the door and reset the air control for the desired heat output within 5 minutes.

Ash Removal

Firebox Ash Removal. This will be required every day or two during normal operation, and is most easily done when the fire has burned down to coals.

When removing the ash pan from a stove that is in operation, close and latch the door before taking the ashes outside for safe disposal. It is always a good idea to wear heavy protective gloves while removing and disposing of the ashes from your stove.

Ashes should be placed in a **metal** container used exclusively for ashes,

with a tight fitting lid. The closed container of ashes should be placed outdoors, well away from all combustible materials, pending final disposal. The ashes should be kept in the closed container until all cinders have thoroughly cooled.

Oven Ash Clean Out. The plate in the bottom of the oven can be removed. Please remove any ash that has built up in the chamber below the oven box. Accumulation will reduce the flow through the stove while in "oven mode" and this will increase the time it takes to get the oven up to temperature. Cleaning the top of the oven is also a good idea. Inspecting through the small stove top coverplate will let you get a better view. Keep the tang on the bottom of the small coverplate towards the front of the stove and out of the way of the slider.

OVERFIRING WILL RESULT IF THE STOVE IS OPERATED WITH THE DOOR OPEN AND THE PIPE DAMPER IN THE FULLY OPEN POSITION.

This could cause damage to the stove, void the warranty or lead to a boat fire.

WARNING:

OPERATE THE HALIBUT ONLY WITH THE DOOR FULLY CLOSED. KEEP THE DOOR FULLY CLOSED EXCEPT WHEN LOADING FUEL OR REMOVING ASHES. A PARTIALLY OPEN DOOR MAY ALSO RESULT IN OVERFIRING.

4. Maintenance

General

Clean the stove's porcelain surface with a soft cloth and soap to remove any accumulations of dirt. **Do not use any abrasive cleansers or aggressive scrubbing pads that might scratch the porcelain.** Clean the stove when it is cool to the touch.

Or, apply as necessary, black stove polish or high temperature paint to a plain iron stove to keep it rust free. By polishing your stove just prior to a period of non-use, you will decrease the chances of your stove rusting while you're away!

Also, make sure that water will not find its way down the chimney pipe. Remove the smoke head and cap the deck iron. Water sitting in the stove can rust-out the bottom of the stove.

At least once a year, perform a routine maintenance check. A good time to do this is when you are cleaning the chimney and smoke head. You should clean the chimney pipe whenever accumulations of soot and **creosote**

reach 1/4” thick, which may be several times a year, depending on how the stove is operated.

1. Thoroughly clean the entire stove. Brush all ash and soot out of the stove. It is better to brush out the ash and soot than to vacuum it out because soot particles are small enough to pass through most vacuum bags. Keep a small wire brush handy to remove any accumulated soot off of the inside of the door.

2. In a dark room, use a strong light to inspect the stove inside and out for cracks or leaks at corners and joints. Cracked parts should be replaced.

WARNING:

IF THIS SOLID FUEL STOVE IS NOT PROPERLY MAINTAINED, A CHIMNEY FIRE MAY RESULT. FOR YOUR SAFETY, FOLLOW THE MAINTENANCE DIRECTIONS AND CLEAN YOUR CHIMNEY FREQUENTLY.

Appendix

*1 ABYC “A-7”

American Boat & Yacht Council Inc.

“A-7” Liquid and Solid Fuel Boat Heating Systems.

*2 NFPA “302”

National Fire Prevention Association

302, Fire Protection Standard for

Pleasure and Commercial Motor Craft 1998 Edition.

*3 NFPA “211”

National Fire Prevention Association

211, Standard for Chimneys, Fireplaces, Vents, and Solid Fuel-Burning Appliances 2000 Edition.

*4 40 CFR 60 - Subpart AAA

Code of Federal Regulations (USA)

Title 40, Volume 6, Part 60 Revised as of July 1, 1999

Standards of Performance for New Residential Wood Heaters.

*5 CAN/CSA B365-M91

Canadian Standards Association Installation Code for Solid Fuel Burning Appliances.

HALIBUT / Limited Warranty

Navigator Stove Works, LLC warrants to the original retail purchaser, that this **HALIBUT Stove** will be free of defects in material and workmanship for a period of FIVE YEARS from the date of purchase on the terms and conditions set forth herein will repair or replace, at its sole option, any part or stove found to be defective. The customer must, at his/her own expense, arrange to deliver or ship the stove or part to NSW and arrange for pickup or delivery of the stove or part after the repairs have been made. If upon inspection, the damage is found to be the fault of the manufacturer the repair or replacement will be made. Any HALIBUT or part thereof that is repaired or replaced during the limited warranty period will be warranted for a period to not exceed the remaining term of the original limited warranty or six (6) months, which ever is longer. This warranty is not transferable and is extended only to, and is solely for the benefit of, the original retail purchaser of the stove. Please retain your dated sales receipt in your records as proof of purchase.

NOTE: The warranties are void if the stove is used to burn materials not outlined in the user manual. Void as well if the stove is not operated according to the owner's manual.

Exclusions & Limitations

This warranty does not cover the following:

Damage due to external causes, not attributable to manufacture or material defect.

Repair or replacements of parts which are subject to normal wear and tear during the warranty period or to parts that may require replacement in connection with normal maintenance.

Damage due to incorrect installations not in conformity with installation instructions, local coast guard regulations, ABYC recommendations, NFPA Regulations.

Damage due to overfiring; causing any part to glow red. Overfiring can be identified by warped plates, or by bubbling, cracking and discoloration of the enamel finish.

Damage caused by unauthorized modification, use or repair.

Damage made while the stove is in transit is not covered by this warranty but is subject to claim against the common carrier (do not operate the stove as this may negate the ability to process the claim with the carrier)

NSW offers no warranty on chipping of enamel surfaces.

Inspect your HALIBUT prior to accepting it from shipper for any damage to the enamel.

IN NO EVENT SHALL Navigator Stove Works, LLC. BE LIABLE FOR SPECIAL INCIDENTAL OR CONSEQUENTIAL DAMAGES. ALL IMPLIED WARRANTIES, INCLUDING THE IMPLIED WARRANTIES OF MERCHANTABILITY AND FITNESS FOR A PARTICULAR PURPOSE, OR OTHERWISE, ARE LIMITED IN DURATION TO THE LENGTH OF THIS WRITTEN WARRANTY. NO ORAL OR OTHER WRITTEN WARRANTY IS ENFORCEABLE.

If you believe that your stove is defective, you should contact NSW, who will process a warranty claim. This warranty is given by Navigator Stove Works, LLC 509 Double Hill Road Eastsound, WA 98245

The customer agrees that Navigator Stove Works, LLC. will not be liable for any consequential and/or incidental damages arising from any cause associated with the goods or services purchased from Navigator Stove Works, LLC.